

Surface Drainage and
Building Elements

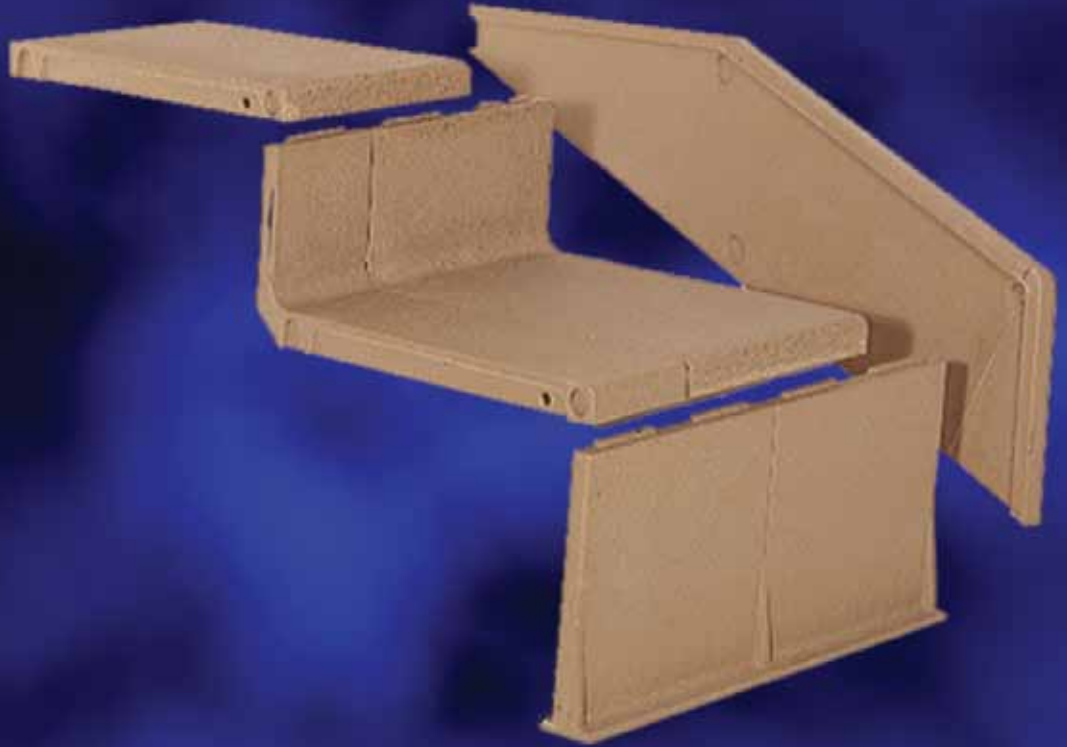

ACO SPORT

System 9000 Bleacher System Product Brochure

Athletic Stadium Terracing and Seating System



System 9000 Bleacher System

System 9000 provides simple all-weather seating and standing areas for spectators in various venues, including courtyards of schools, sporting areas — football, baseball, basketball, hockey fields, tennis courts, outdoor swimming pools, and race tracks — and parks and amphitheaters.

Bleacher seating comprises of polymer concrete, interlocking units, that fit together to form a multi-level terrace system with step and seat options.

ACO recommends a maximum height of 20 step or 10 seating elements (approximately 12.5ft high).

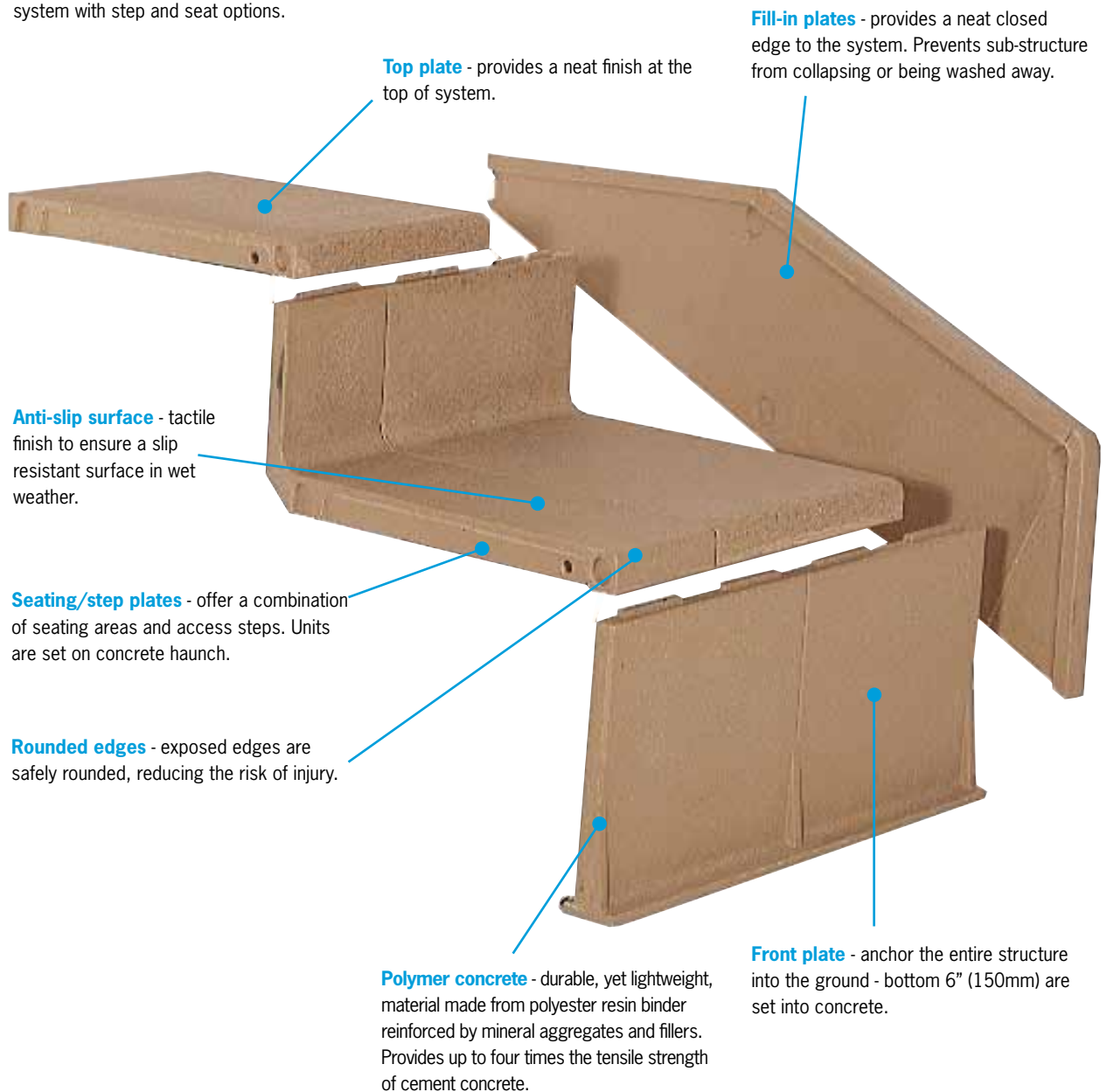

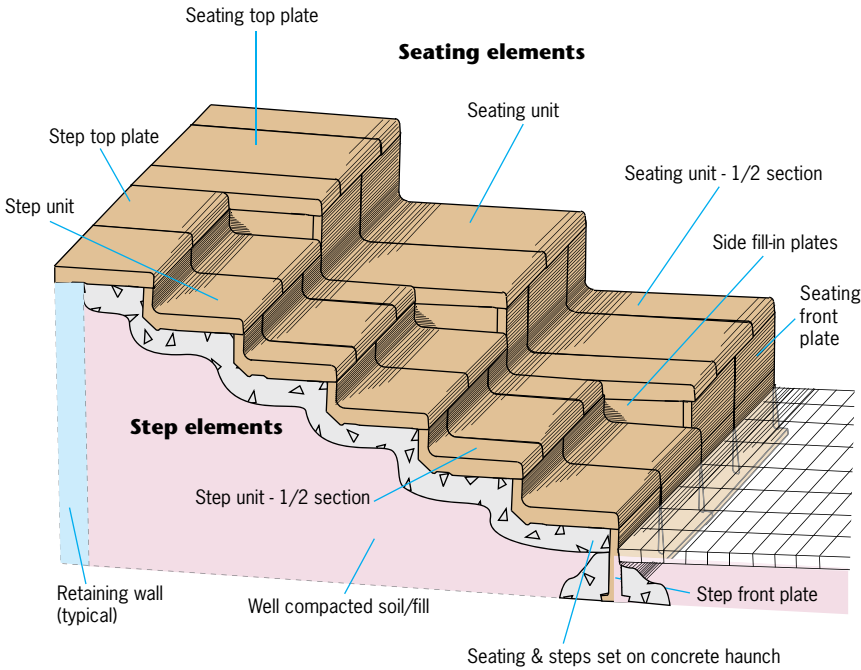

Step elements

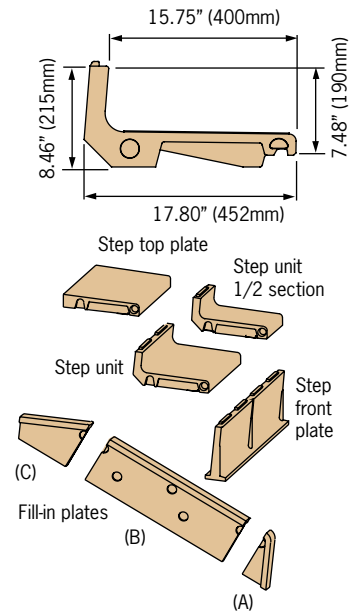

Seating elements

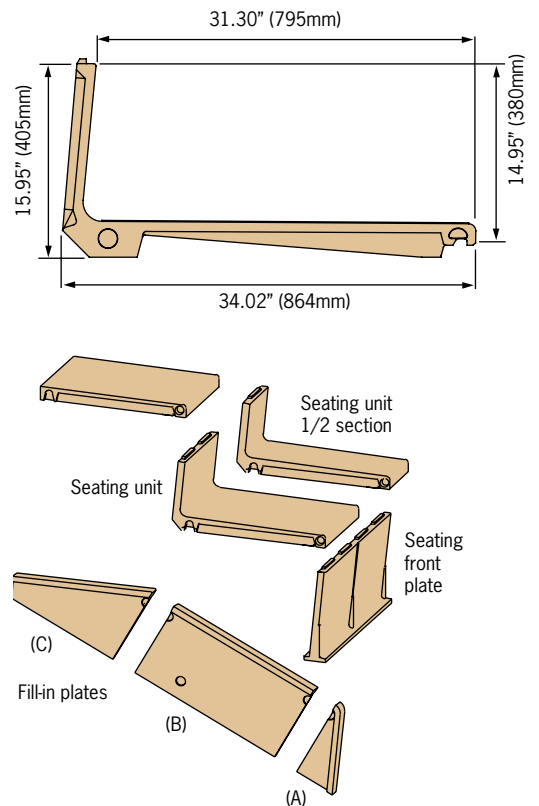

Product Table

	Part No.	Length in. (mm)	Width in. (mm)	Height in. (mm)	Wgt (lbs)
Step components					
Front plate	00161	39.4 (1000)	1.6 (40)	11.0 (280)	41.8
Standing unit	00154	19.7 (500)	15.7 (400)	7.5 (190)	57.2
Standing unit- 1/2 section	00155	9.8 (250)	15.7 (400)	7.5 (190)	28.6
Top plate	00165	19.7 (500)	15.0 (380)	2.9 (75)	33.0
Top plate - 1/2 section	00166	9.8 (250)	15.0 (380)	2.9 (75)	17.6
Lower fill-in plate (A)	00164	5.9 (150)	2.4 (60)	11.0 (280)	4.4
Middle fill-in plate (B)	00162	34.7 (880)	2.4 (60)	11.0 (280)	30.8
Top fill-in plate (C)	00163	13.4 (340)	2.4 (60)	11.0 (280)	8.8
Transition components					
Side fill-in plate (right)	00194	16.5 (420)	1.2 (30)	7.5 (190)	6.6
Side fill-in plate (left)	00208	16.5 (420)	1.2 (30)	7.5 (190)	6.6
Seating components					
Front plate	00181	39.4 (1000)	1.6 (40)	18.9 (480)	61.6
Seating unit	00170	19.7 (500)	31.5 (800)	15.0 (380)	94.6
Seating unit- 1/2 section	00171	9.8 (250)	31.5 (800)	15.0 (380)	46.2
Top plate	00186	19.7 (500)	30.7 (780)	2.9 (75)	66.0
Top plate - 1/2 section	00187	9.8 (250)	30.7 (780)	2.9 (75)	35.2
Lower fill-in plate (A)	00184	7.9 (200)	2.4 (60)	17.3 (440)	8.8
Middle fill-in plate (B)	00182	34.7 (880)	2.4 (60)	17.3 (440)	66.0
Top fill-in plate (C)	00183	29.5 (750)	2.4 (60)	17.3 (440)	24.2



Other ACO SPORT systems

- **System 1000**
The premier running track drain system with canopy cover.
- **System 2000**
A premier slotted running track drain system as used on IAAF tracks.
- **System 3000**
The economical, general purpose running track slot drain system used by colleges and schools.
- **System 4000**
An open channel drain with removable grates. Ideal for tennis courts and general sport field use.
- **System 6000**
The premier open channel drain system with synthetic turf clamping device.
- **System 7000**
Sand traps, rubber capped curbs and aluminum covers to fit around sand pits used for long jump and high jump.
- **System 8000**
A series of accessories for water jump, pole vault and throwing disciplines.

ACO Polymer Products, Inc.

East Sales Office

P.O. Box 245
Chardon, OH 44024
Tel: (440) 285-7000
Toll free: (800) 543-4764
Fax: (440) 285-7005

West Sales Office

P.O. Box 12067
Casa Grande, AZ 85130
Tel: (520) 421-9988
Toll Free: (888) 490-9552
Fax: (520) 421-9899

Electronic Contact:

info@acousa.com
www.acousa.com



© October 2009 ACO Polymer Products, Inc.

All reasonable care has been taken in compiling the information in this document. All recommendations and suggestions on the use of ACO products are made without guarantee since the conditions of use are beyond the control of the Company. It is the customer's responsibility to ensure that each product is fit for its intended purpose and that the actual conditions of use are suitable. ACO Polymer Products, Inc. reserves the right to change products and specifications without notice.

Re-order Part # AS032